

SIERRA - RACK SYSTEM

User Manual V1.3

THE NEW GENERATION OF POWER CONVERTERS

- » **DUAL AC AND DC OUTPUT CONVERTER**
Commercial Power as default source
- » **AC AND DC BACKUP IN A DC ENVIRONMENT**
Leverage your existing DC infrastructure
- » **ONE STOP SHOP**
Wide output power range
- » **HARSHEST AC INPUT CONDITIONS**
Without compromising the quality of the AC output



Important Safety Instructions
Save these Instructions

Table of content

1. CE+T at a glance	5
2. Abbreviations	6
3. Warranty and Safety Conditions	7
3.1 Disclaimer	7
3.2 Technical care	7
3.3 Installation	8
3.3.1 Handling.....	8
3.3.2 Surge and transients	9
3.3.3 Other.....	9
3.4 Maintenance	9
3.5 Replacement and Dismantling.....	9
4. ECI Technology	10
4.1 Backup Mode.....	11
4.2 EPC-mode.....	11
4.3 Walk-in mode.....	11
5. Description	12
5.1 Sierra Rack System Advanced Features:.....	13
6. Components	15
6.1 Sierra Module.....	15
6.2 Monitor Unit - INVIEW S.....	16
6.3 Measure Box Battery	17
7. Installation	18
7.1 Unpacking the system.....	18
7.2 Installing the System into a Cabinet.....	18
7.3 Sliding out the Upper Part.....	19
7.4 Electrical Installation	20
7.4.1 Pre-requisites.....	20
7.4.2 Cable Routing and Fixation	20
7.4.3 Power Terminals.....	21
7.4.4 DC Input.....	22
7.4.5 AC Input	22
7.4.6 AC Output.....	22
7.4.7 Grounding	22
7.4.8 Signalling	23
8. Operation.....	24
8.1 Converter module.....	24
8.2 Sign Convention	25
8.3 User GUI Interface - Inview S.....	25
8.3.1 Hierarchy	25
8.3.2 Interface Areas	26
8.3.3 Pages and Feature.....	27



Leading AC Backup Technology

8.4	User WEB Interface.....	30
9.	System Start-up.....	32
9.1	Initial state	32
9.2	Installation Check.....	32
9.3	Start-up	32
10.	Inserting/removing/replacing modules	34
10.1	ECI Converter	34
10.1.1	Removal.....	34
10.1.2	Inserting.....	34
10.2	Fan replacement	35
11.	Commissioning	36
12.	Service	38
13.	Maintenance Task	39
13.1	Spare Parts	39



Leading AC Backup Technology

Release Note:

Version	Release date (DD/MM/YYYY)	Modified page number	Modifications
1.0	23/10/2017	-	First release of the Manual.
1.1	15/11/2017	-	Amendment and correction.
1.2	12/03/2018	-	Updated as per revised design.
1.3	04/04/2018	-	Updated information and Illustrations.



Leading AC Backup Technology

CE+T at a glance

1. CE+T at a glance

CE+T Power designs, manufactures and markets a range of products for industrial operators with mission critical applications, who are not satisfied with existing AC and DC backup systems performances, and related maintenance costs.

Our product is an innovative AC and DC backup solution that unlike most used UPS's

- Maximizes the operator's applications uptime;
- Operates with lowest OPEX;
- Provides best protection to disturbances;
- Optimizes footprint.

Our systems are:

- Modular
- Truly redundant
- Highly efficient
- Maintenance free
- Battery friendly

CE+T power puts 60+ years expertise in power conversion together with worldwide presence to provide customized solutions and extended service 24/7 - 365



2. Abbreviations

ECI	Enhanced Conversion Innovation
EPC	Enhanced Power Conversion
REG	Regular
DSP	Digital Signal Processor
AC	Alternating current
DC	Direct current
ESD	Electro Static Discharge
MET	Main Earth Terminal
MBP	Manual By-pass
TCP/IP	Transmission Control Protocol/Internet Protocol
USB	Universal Serial Bus
PE	Protective Earth (also called Main Protective Conductor)
N	Neutral
PCB	Printed Circuit Board
TRS	True Redundant Structure
MCB	Miniature Circuit Breaker
MCCB	Molded Case Circuit Breaker
CB	Circuit Breaker



3. Warranty and Safety Conditions*

WARNING:

The electronics in the power supply system are designed for an indoor, clean environment.

When installed in a dusty and/or corrosive environment, outdoor or indoor, it is important to:

- Install an appropriate filter on the enclosure door, or on the room's air conditioning system.
- Keep the enclosure door closed during operation.
- Replace the filters on a regular basis.

Important Safety Instructions and Save These Instructions.

3.1 Disclaimer

- The manufacturer declines all responsibilities if equipment is not installed, used or operated according to the instructions herein by skilled technicians according to local regulations.
- Warranty does not apply if the product is not installed, used and handled according to the instructions in the manuals.

3.2 Technical care

- This electric equipment can only be repaired or maintained by a "qualified employee" with adequate training. Even personnel who are in charge of simple repairs or maintenance are required to have knowledge or experience related to electrical maintenance.
- Please follow the procedures contained in this Manual, and note all the "DANGER", "WARNING" AND "NOTICE" marks contained in this manual. Warning labels must not be removed.
- Qualified employees are trained to recognize and avoid any dangers that might be present when working on or near exposed electrical parts.
- Qualified employees should know how to lock out and tag out machines, so the machines will not accidentally be turned on and injure employees working on them.
- Qualified employees also understand safety related work practices, including those by OSHA and NFPA, as well as knowing what personal protective equipment should be worn.
- All operators are to be trained to perform the emergency shut-down procedure.
- Operating ambient temperature is -20°C to 50°C.
- This unit is intended for installation in a temperature-regulated, indoor area that is relatively free of conductive contaminants.
- Never wear metallic objects such as rings, watches, or bracelets during installation, service or maintenance of the product.
- This product is suitable for use in a computer room.

* These instructions are valid for most CE+T Products/Systems. Some points might however not be valid for the product described in this manual



Warranty and Safety Conditions

- **CAUTION** – Risk of electric shock. Capacitors store hazardous energy. Do not remove cover until 5 minutes after disconnecting all sources of supply.
- **CAUTION** – Risk of electric shock. This Converter / UPS receives power from more than one source. Disconnection of the AC source and DC source is required to de-energize this unit before servicing.
- **CAUTION** - For continued protection against risk of fire, replace only with same type and rating of fuse.
- Insulated tools must be used at all times when working with live systems.
- When handling the system/units pay attention to sharp edges.

3.3 Installation

- This product is intended to be installed only in a restricted access area as defined by UL 60950 and in accordance with the National Electrical Code ANSI/NFPA 70, or equivalent local agencies.
- The Converter System may contain output over-current protection in the form of circuit breakers. In addition to these circuit breakers, the user must observe the recommended UL listed upstream and downstream circuit breaker requirements as defined in this manual.
- UL listed (DIVQ) branch overcurrent protections have to be provided by others / by customer.
- Please use extreme caution when accessing circuits that may be at hazardous voltages or energy levels.
- The Converter rack is a dual input power supply. The complete system shall be wired in a way that both input and output leads can be made powerfree in a single action.
- REG systems can be seen as independent power sources. To comply with local and international safety standards N (output) and PE shall be bonded.
- EPC system that have no AC input wired and connected to comply with local and international safety standards N (output) and PE shall be bonded. The bonded between N output and L must be removed once the AC input is being connected.
- When AC Mains is not connected, the output AC circuit is considered as a separately-derived source. If local codes require grounding of this circuit, use the identified terminal for bonding this circuit to the enclosure. Ground the enclosure to a suitable grounding electrode in accordance with local code requirements. Ground the enclosure to the electrode terminal (see section 7.4.7, page 22).
- Use 90°C copper wires / conductors only.
- AC and DC circuits shall be terminated with no voltage / power applied.
- The safety standard IEC/EN62040-1-1 requires that, in the event of an output short circuit, the converter must disconnect in 5 seconds. The parameter can be adjusted on T2S; however, if the parameter is set at a value > 5 seconds, an external protection must be provided so that the short circuit protection operates within 5 seconds. Default setting is 60 seconds.
- All illustrations in the manual are for general reference, Refer to the technical drawing which is received along with the system for exact information

3.3.1 Handling

- The cabinet shall not be lifted using lifting eyes.
- Remove weight from the cabinet by unplugging the converters. Mark converters clearly with shelf and position for correct rebuild. This is especially important in dual or three phase configurations.
- Empty converter positions must not be left open. Replace with module or cover.

Warranty and Safety Conditions

3.3.2 Surge and transients

The mains (AC) supply of the modular converter system shall be fitted with Lightning surge suppression and Transient voltage surge suppression suitable for the application at hand. Manufacturer's recommendations of installation shall be adhered to. Selecting a device with an alarm relay for function failure is advised.

Indoor sites are considered to have a working lightning surge suppression device in service.

- Indoor sites Min Class II.
- Outdoor sites Min Class I + Class II or combined Class I+II.

Note:

Choosing and installing surge arrestors must obey to precise technical rules. Distance to equipment to protect, cable gage and cable routing have significant influence on proper device service.

Some areas are more susceptible to be hit by electrical strikes, especially when altitude increases.

Good earthing is also crucial for surge arrestors to work properly.

CE+T declines any liability in regard to damaged caused to equipment not correctly or not sufficiently protected.

3.3.3 Other

- Isolation test (Hi-Pot) must not be performed without instructions from the manufacturer.

3.4 Maintenance

- The converter system/rack can reach hazardous leakage currents. Earthing must be carried out prior to energizing the system. Earthing shall be made according to local regulations.
- Prior to any work conducted to a system/unit, make sure that AC input voltage and DC input voltage are disconnected.
- Prior to accessing the system or modules, make sure all source of supply is disconnected.
CAUTION – Risk of electric shock. Capacitors store hazardous energy. Do not remove cover until 5 minutes after disconnecting all sources of supply.
- Some components and terminals carry high voltage during operation. Contact may result in fatal injury.

3.5 Replacement and Dismantling

- ESD Strap must be worn when handling PCB's and open units.
- The converter system/rack is not supplied with internal disconnect devices on input nor output
- CE+T cannot be held responsible for disposal of the converter system and therefore the customer must segregate and dispose of the materials which are potentially harmful to the environment, in accordance with the local regulations in force in the country of installation.
- If the equipment is dismantled to dispose of its component products, you must comply with the local regulations in force in the country of destination and in any case avoid causing any kind of pollution.

To download the latest documentation and software, please visit our website at www.cet-power.com

4. ECI Technology ¹

Sierra modules carrying the ECI logo and the EPC mark are triple port converters (AC in, DC in, AC out). Sinusoidal output is converted from Mains or/and DC.

The block diagram below gives an explicit description of the topology and operation.

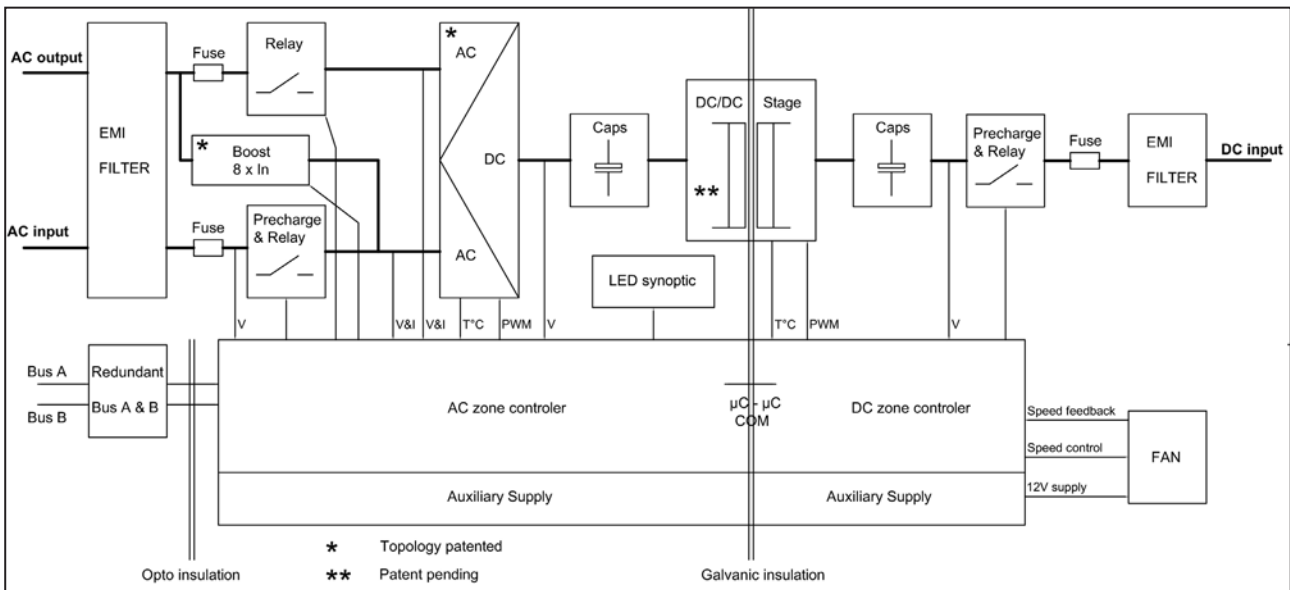

The module is built around the following sub-converters

- AC to DC at input
- DC to DC at input
- DC to AC at output

The energy can flow either from the AC source or the DC source under the control of the local DSP controller. Thanks to internal energy buffering, the output sine wave is constant and disturbance free regardless of the active source.

The BOOST functionality multiplies the nominal current for a period of 20 ms (max) in the event of down stream failures. The upstream breakers do not have to be oversized to prevent tripping. The overload capacity is 150% for 15 seconds.

The ECI works according to True Redundant Structure (TRS) that features decentralized and independent logic, redundant communication bus and three internal levels of disconnection to isolate a module after internal failure.

This functionality is included in every converter module. Running them in parallel provides a modular system with, no single point of failure, always-conditioned output, high system efficiency and 0 ms source transfer time.

¹ Information and data given in this chapter is intended to serve as an overview of the ECI Technology. Detailed features and parameters for each individual module type in the range may differ and should be referred to in the dedicated data sheet.



4.1 Backup Mode

DC is the primary source of supply whilst Mains (AC) works as the secondary source. Switching time between DC input and AC input is 0 ms (source transfer). The power delivered by the DC source (usually a battery, but possibly any other type of DC generator) is converted to provide regulated and transient-free power to the load. In the event of a short circuit on the load side, the boost is automatic, timely and energized for a specific duration to trip downstream protective devices.

4.2 EPC-mode

Mains input (AC) is the primary source whilst DC works as backup.

The ECI is designed to operate on Mains on a permanent basis and to deliver output voltage conditioned with low THD.

The output sine wave is physically independent of whether the source is AC (or) DC. If the Mains is out of tolerance or goes down, the converter seamlessly switches to DC and the converter operates in “Back-up mode” (Changeover switching time is 0 ms).

As soon as the Mains returns to its valid range, the EPC mode is automatically resumed.

The EPC mode offers higher efficiency (up to 96% depending on the model) without compromising the purity of the output sine wave.

4.3 Walk-in mode

Under some circumstances the DC and AC sources can be combined. The sequence is defined by a user selectable set of parameters. Start, control and exit are fully automatic.

A specific example of Mix-mode is the Walk-in mode where the transfer from DC source to AC source is ramped up within a fixed and adjustable period of time.

5. Description

Sierra Rack secure AC and DC critical loads by taking energy from AC input (Grid) or from the DC Input (Battery).

Sierra Rack System has been designed to give quality power, ease of use, and reliability. It can be installed in 19 inch cabinet.

Normal Mode

When AC input is present, the SIERRA module takes energy from AC source to feed:

- AC Load via a double conversation to provide full sinus established 230 VAC.
- DC loads and charging the battery with a regulated 48 VDC.

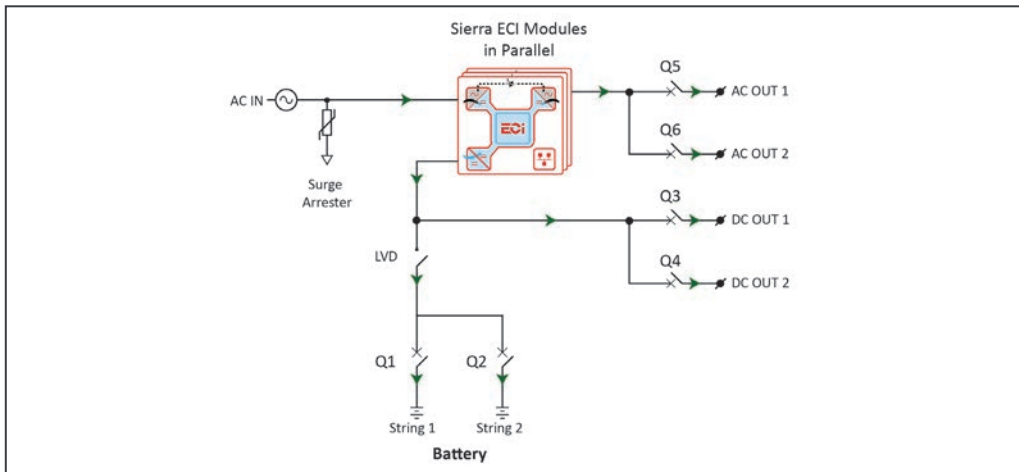

Sierra Rack System - Normal Mode Operation

Backup Mode (No AC input)

In case of no AC input, the sierra module take energy from the battery and feed AC load via a double conversation to provide full sinus established 230 VAC.

DC load are directly supplied from battery.

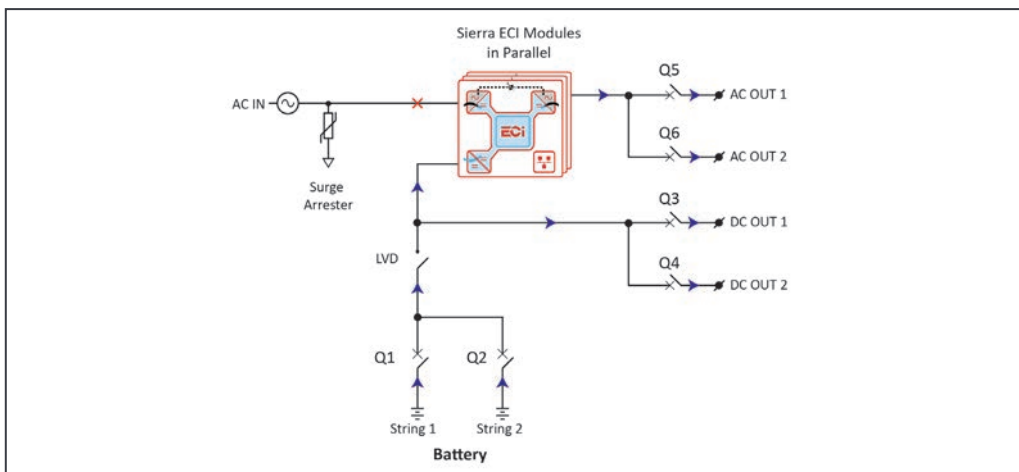

Sierra Rack System - Reg Mode Operation

5.1 Sierra Rack System Advanced Features:

- Secure AC and DC critical loads.
- Peak shaving function which allows to define the limit of power taken from AC input. If the total load DC+ AC exceed the preset limits the system will compensate with the DC source (battery).
- 3 phase balancing (Available on 3 Phase Configuration)
- Low voltage Battery Disconnection (LVD)

Sierra Rack System Configurations.

S.No	Product Name	AC Input	AC Output	DC Input (Battery)	DC Output	Number of ECI Modules	Output Power (AC and DC Load)
	Sierra 2.4 KW Single Phase	230 VAC 50 Hz	2 x 230 VAC 16 A 1P	2 x 48 VDC 125 A	2 x 48 VDC 125 A	1 + 1*	2.4 kW
S72P73E0304 S2000J001	Sierra 4.8 KW Single Phase	230 VAC 50 Hz	2 x 230 VAC 16 A 1P	2 x 48 VDC 125 A	2 x 48 VDC 125 A	2 + 1*	4.8 KW
	Sierra 7.2 KW Single Phase	3 x 400 VAC + N 50 Hz	2 x 230 VAC 16 A 1P	2 x 48 VDC 125 A	2 x 48 VDC 125 A	3	7.2 KW

*: Number of redundancy modules.

The weight of the system without module is 23 Kg.

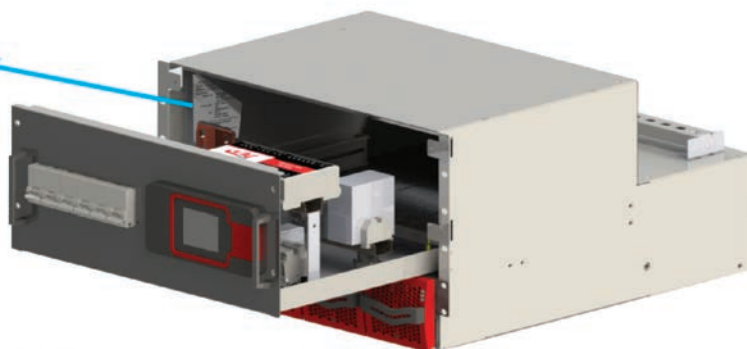
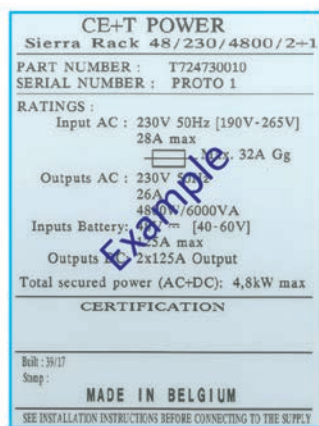

Refer your system type by using rating label which is located on the system top compartment.

Description



Sierra Rack System - General Dimensions

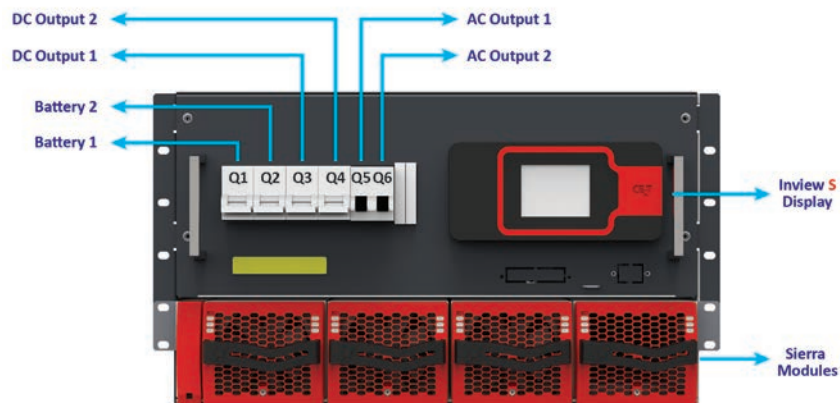

System Front View - Details

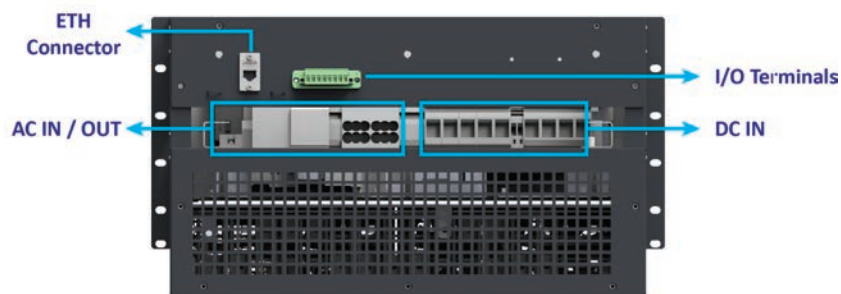

System Rear View - Details

6. Components

6.1 Sierra Module

Each SIERRA module can supply 2.4 kW on any DC or AC output ports. The AC input stage rated to 2.7 kW offering power excess for battery charging with AC load 2.4 kW.

- The Sierra module is a 3000 VA / 2400 W triple port converter.
- The Sierra modules are hot swappable and hot pluggable.
- The module operator interface is LEDs showing converter status and output power.
- The converter modules is equipped with soft start.
- Fan is equipped with alarm and run time meter. The fan is field replaceable.
- 435 mm (D) x 102 mm (W) x 88 mm (H).
- 5 Kg.



6.2 Monitor Unit - INVIEW S

Inview S GUI Interface is a standard controller for ECI technology based bi directional products.

It is a powerful web based touch screen graphical display, it allows user to easily access, monitor the system and protected with PIN code.

In addition to the touch screen a web interface is accessible via ETH port.

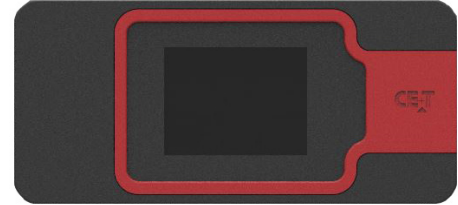

- Measures
 - AC IN
 - AC OUT
 - DC
 - Module Information
- 3 LED's (OK - Green, Minor Alarm - Orange, Major Alarm - Minor)
- 2 outgoing alarm contacts (1 - Minor and 1 - Major).
- 2 Digital Inputs
- 2.8" touch screen
- Web browser with laptop (ETH, SNMP, MQTT, Modbus, CAN,....)
- Height: 2U



Inview S - Termination Details

6.3 Measure Box Battery



Measure Box Battery is composed of multiple analog and digital inputs and outputs. They are used for:

- Battery management
 - Temperature
 - Current
 - Voltage
 - Low voltage disconnection
- Alarm Relays
- Measure box contains:
 - 6 Output Relay
 - 6 Digital Input

7. Installation

7.1 Unpacking the system

Modules are packed separately.

The packing material of the ECI system is recyclable.

7.2 Installing the System into a Cabinet

Sierra Rack System is designed for 19-inch mounting applications.

- 19" – 600 mm depth cabinets.
- 19" – 800 mm depth cabinets.

Warning: The modules should be placed in their slot, only after the proper installation.

Perform the following steps to fix the Sierra Rack System in 19 inch cabinet.

Step 1. Fix the Brackets and bottom support using the screws which is supplied along with the kit.

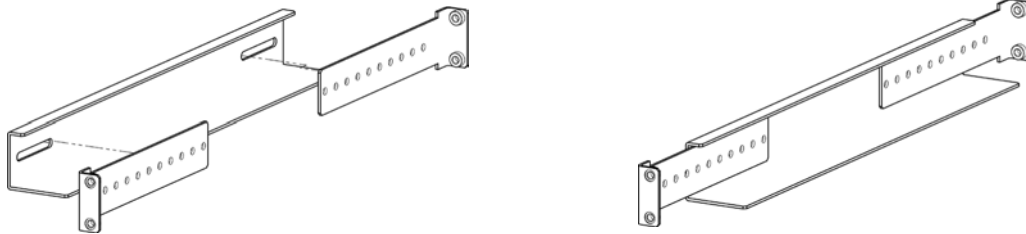

Step 2. Fix the assembled brackets and bottom support into the 19 inch rack.

Step 3. Place the Sierra System in the 19 inch rack and fix it with supplied screws (5 screws on each sides).

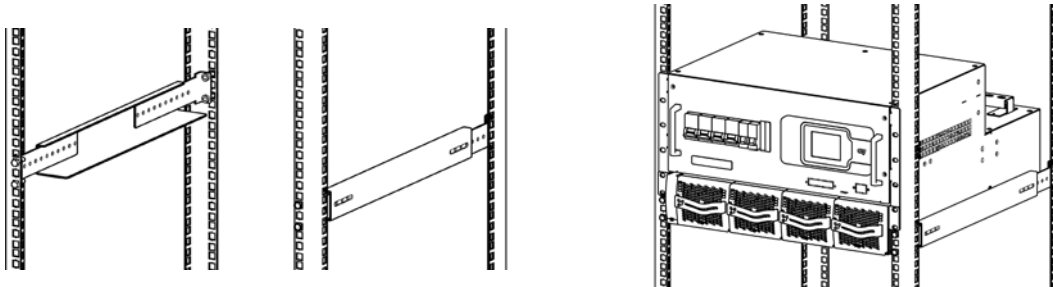

Step 4. Verify the correct slot for each module and place the module.

Note: Air inlets are at the front of the system and air exhaust outlets are at the rear of the system. Keep system rear area free of 50 mm.

7.3 Sliding out the Upper Part

The AC IN and OUT, DC IN and OUT, and other terminals are present in the upper part of the system, in order to access these terminals you can slide out the upper part alone.

Caution:

Risk of electric shock, this system receives power from more than one source.

Perform the following steps to slide out the upper part:

Step 1. Remove all the four screws in the upper part of the system.

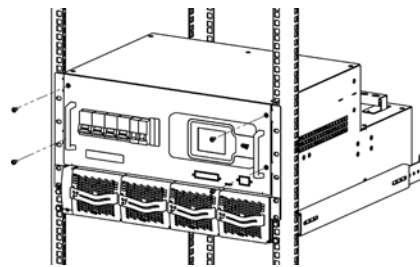
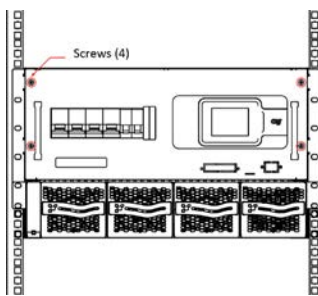

Step 2. Using the front handle, pull out the upper part.

Note: The upper part of the Sierra System can slide out maximum of 340 mm from its original position.

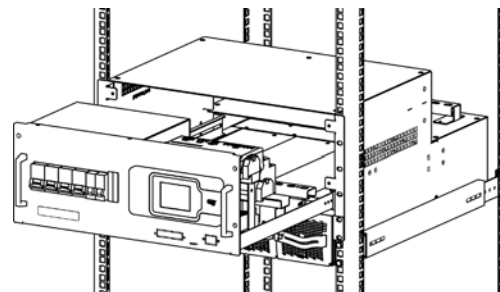
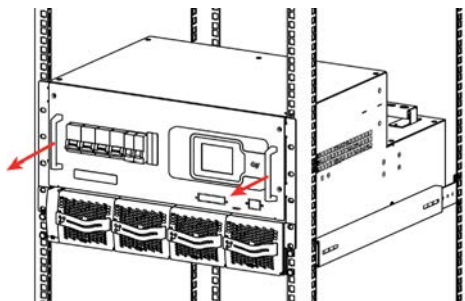

7.4 Electrical Installation

7.4.1 Pre-requisites

- The system have markings for all terminations.
- All cables shall be rated at min 90° C.
- Electrical terminations shall be tightened with 5 Nm.
- DC Connections: Observe Polarity.
- AC Connections: Respect Phases.
- Wire all positions in the system as per markings.
- Input AC / Output AC / Input DC / Signal cables shall be separated.
- Cable crossings shall be done at 90° angles.

7.4.2 Cable Routing and Fixation

All the cable routings are made through rear side of system.

Tie all the entry cables in the C-Rail which is present at upper part of the system. Also optional C-Rail is provided at rear side of the system, refer the following image

Note: Provide appropriate length for input and output cables, so that while pulling out the system upper part the cables should not obstruct the sliding.



7.4.3 Power Terminals

Sierra Rack System termination are marked in the following figure.

Refer to the marking present inside the system and in electrical drawing which came along with the system.

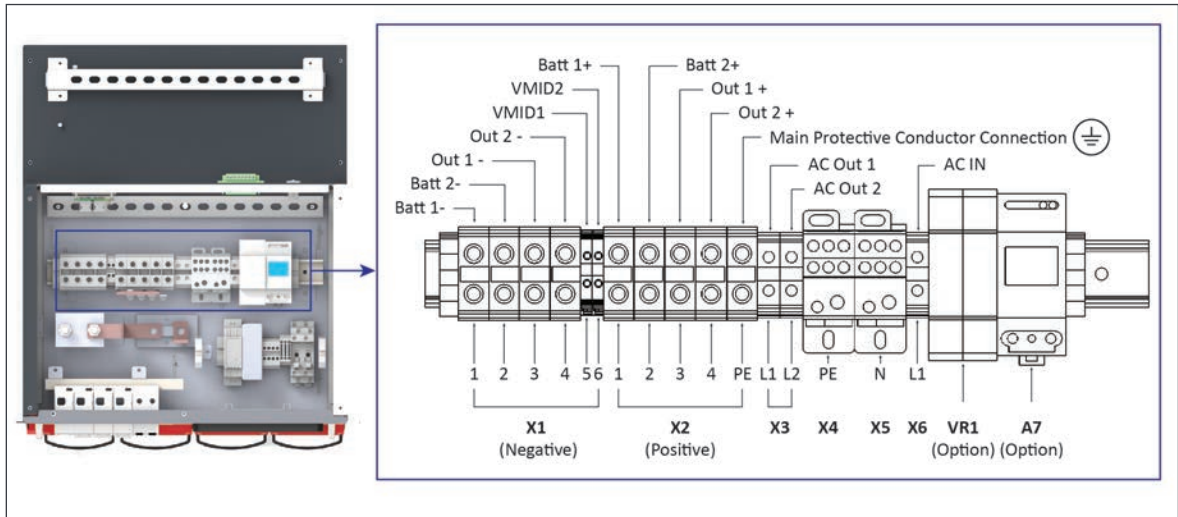

An optional Jumper can be placed between DC IN Positive and PE terminal. The altering may require at the terminal top part (X2-4 and X2-PE) in order to screw the jumper.

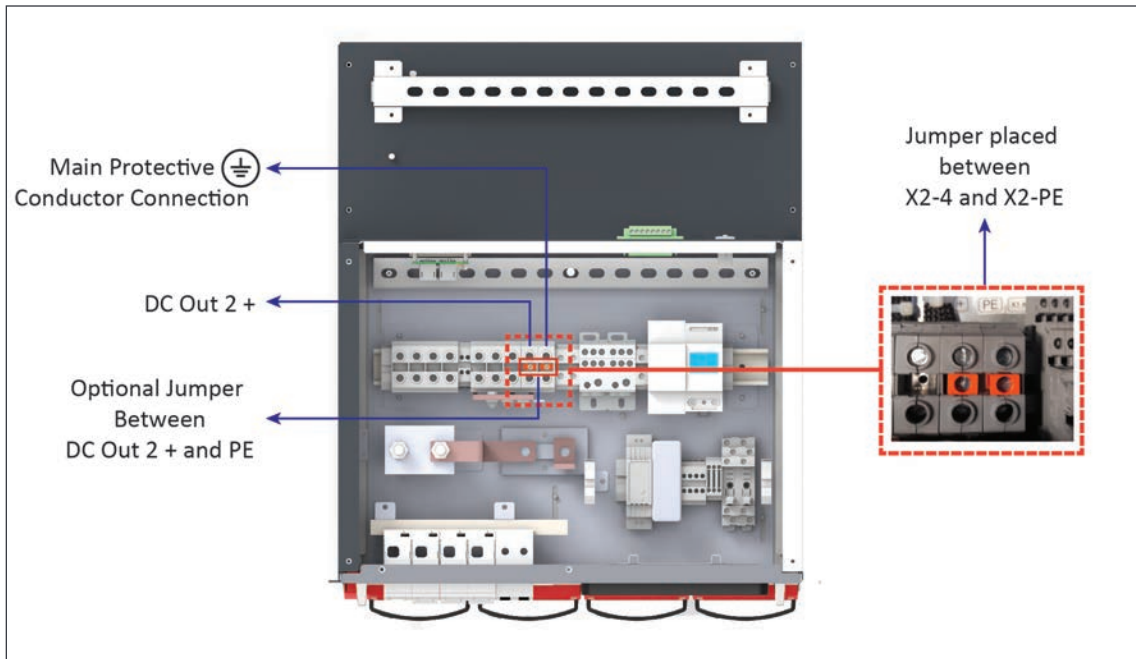

7.4.4 DC Input

Voltage	Battery Input			DC Output			Lug
	Internal Protection	Recommended Cable	Terminal Capacity	Internal Protection	Recommended Cable	Terminal Capacity	
48 VDC	2 X MCB C-125 A	35 mm ²	35 mm ²	2 X 125 A	35 mm ²	35 mm ²	Insulated Pin type

7.4.5 AC Input

Voltage	Protection	Recommended Cable	Terminal Capacity	Lug
230 VAC	MCB C-40 A Must be installed Externally	10 mm ²	10 mm ²	Insulated Pin type

It is recommended to install appropriate breaker at AC input and place a warning label near the breaker stating message as “**ISOLATE UNINTERRUPTIBLE POWER SUPPLY (UPS) BEFORE WORKING ON THIS CIRCUIT**”.

7.4.6 AC Output

Voltage	Internal Protection	Recommended Cable	Terminal Capacity	Lug
230 VAC	2 x MCB C-16 A 1P	1 x 2.5 mm ²	10 mm ²	Insulated Pin type

7.4.7 Grounding

Main protective conductor (PE) connection is made to the X2 (DC IN) terminal block marked with symbol for identification.

PE must be terminated even if commercial Mains is not available and must be connected to building or main panel ground. Recommended Cable cross section is 10 mm² (min). Adhere to local regulations.

Ground has to be connected in accordance with local code. 



7.4.8 Signalling

ETH bus and I/O terminals are available at the rear or front (optional) side of the rack.

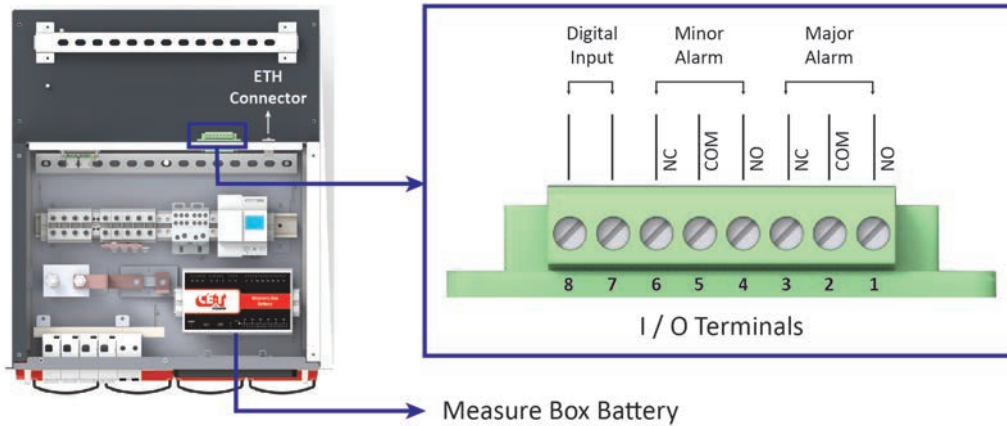

Relay characteristics (K1 to K6 - UA and NUA)

Switching Power	Rating		Recommended Cable	Terminal Capacity	Lug
	30 Vdc	60 Vdc			
60 W	2 A	1 A	0.5 mm ²	2.5 mm ²	Insulated Pin type

Digital Input characteristics

Signal Voltage	Recommended Cable	Terminal Capacity	Lug
+50 Vdc (Galvanically insulated)	0.5 mm ²	2.5 mm ²	Insulated Pin type

7.4.8.1 Temperature Sensor

Temperature probe is supplied along with the system of length 3.5 m. One end of this probe is connected at T1 terminal (Pin 40 & 41) in Measure Box Battery.

Note: By request other lengths probe is available as option.

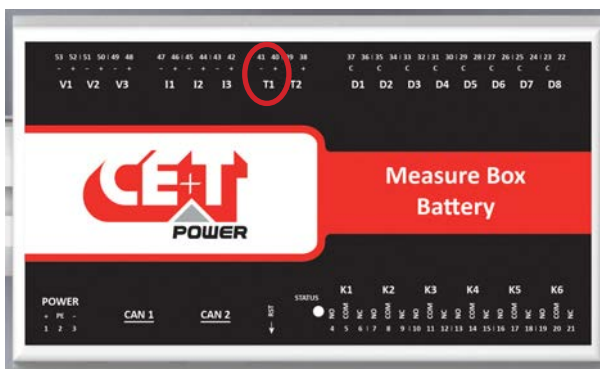

8. Operation

8.1 Converter module

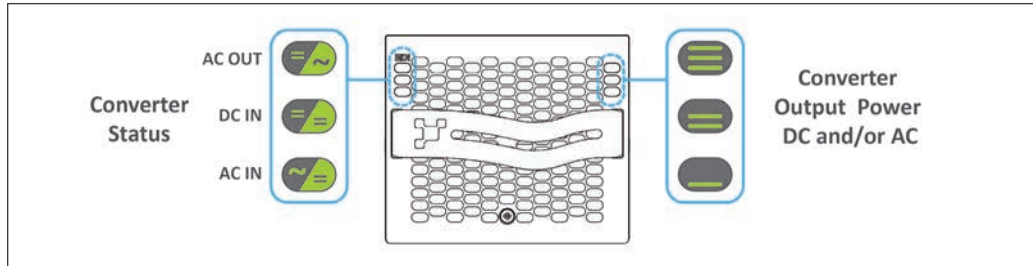

Converter Status LED	Description	Remedial action
OFF	No input power or forced stop	Check environment
Permanent green	Operation	
Blinking green	Converter OK but working conditions are not fulfilled to operate properly	
Blinking green/orange alternatively	Recovery mode after boost (10 In short circuit condition)	
Permanent orange	Starting mode	
Blinking orange	Modules cannot start	Check Monitoring.
Blinking red	Recoverable fault	
Permanent red	Non recoverable fault	Send module back for repair

AC Output Power (redundancy not counted)						
<5%	5% to 40%	40 to 70%	80 to 95%	100%	100% = overload	Output Power (redundancy not counted)
×	×	×	≡	≡	≡	Status output power LED
×	×	=	=	=	=	
—	—	—	×	—	—	
1B	1P	2P	2P	3P	3B	Behaviour (B = Blinking – P = Permanent)

8.2 Sign Convention

All AC and DC gates of Sierra Module are bi-directional and so can act as a load or as a source depending of the operation. The following picture shows the sign convention used for current and power measurement.

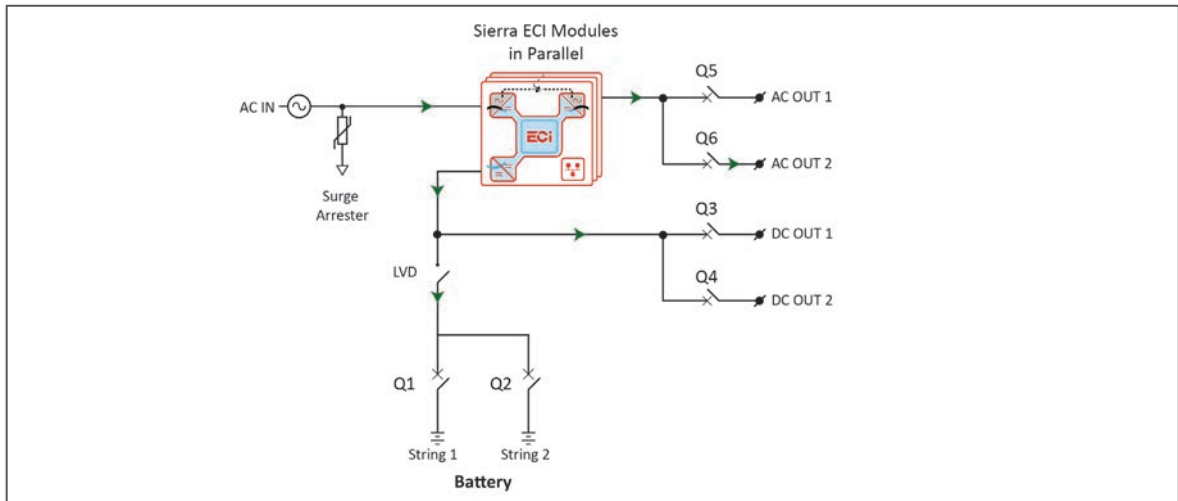

Monitoring - Current and Power sign convention

8.3 User GUI Interface - Inview S

Once system is powered upon, the Inview S is up and ready for operation.

Configuration and other parameters can be changed using the Inview S interface.

Inview S provides a quick and efficient user interface to:

- Overview of the system information
- Detail information on
 - AC input power at system level
 - AC output power at system level
 - DC information at system level

Home		
AC In 1	DC 1	AC Out 1
223.0 V	Float	223.0 V
11.0 A	54.0 V	2.0 A
2.5 kW	37.3 A	0.4 kW
100% - 19'		
MOD	RED	INST
3	OK	7.8 kW

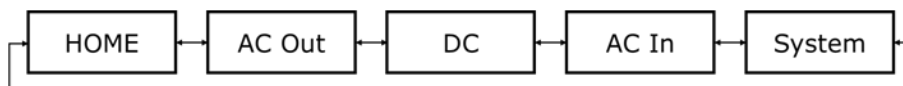

8.3.1 Hierarchy

By default, home will be displayed. Monitoring pages are available in a circular list

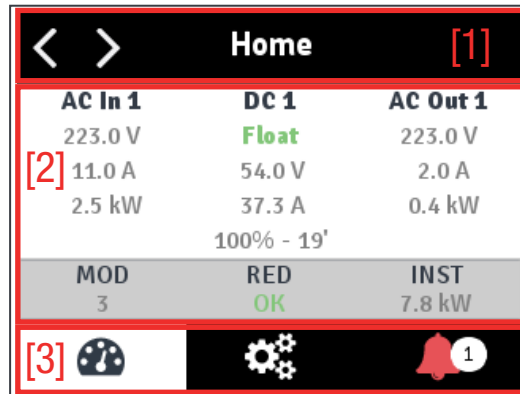

8.3.2 Interface Areas



Home [1]		
AC In 1	DC 1	AC Out 1
223.0 V	Float	223.0 V
[2] 11.0 A	54.0 V	2.0 A
2.5 kW	37.3 A	0.4 kW
100% - 19'		
MOD	RED	INST
3	OK	7.8 kW
[3] 		 1

- [1] Banner

Displays the title of the current page and navigation buttons for next and previous page. If more contents on the main area, Up and Down navigation buttons will be present.

- [2] Main Area

Provides the information about selected page. It can be measures, logs, or even controls.

- [3] Toolbar

The toolbar is always accessible and provide quick access to following pages:

- Measures
- Controls
- Alarms and Logs

Note: In certain conditions the pop up can be displayed and it hides the tools bar, replacing by a “close” or any other call to action control. But the banner will be always present.

8.3.3 Pages and Feature

8.3.3.1 Home Page

Home page gives an overview of system status in one page.

AC in column displays the voltage (V), current (A) and power (kW) of the AC input. In the multi input phase system, displays the power as the sum of all phases.

DC column displays the battery mode, voltage (V), current (A) and battery's SoC and estimated remaining time.

AC Out column displays the output configuration is given (1P, 2P or 3P). Measures are provided overall. Voltage (V), current (A) and power (kW) are available.

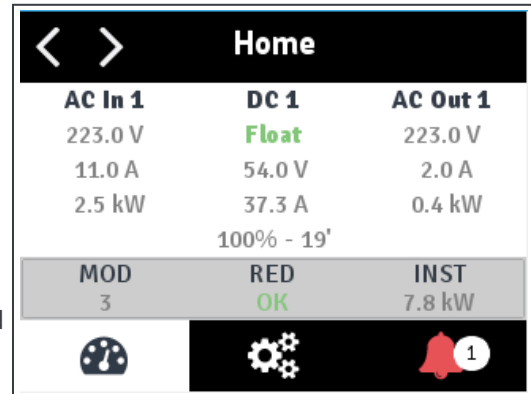

The grey bar provides few extra status:

- **MOD** - Number of modules configured in the system
- **RED** - Redundancy satisfied or not
- **INST** - Installed Power

8.3.3.2 AC Out Page

This page displays the measurement made by the modules on the AC output.

Available values are:

Measure	Unit
Voltage (V)	Volts (V)
Current (I)	Ampere (A)
Active Power	Kilo Watt (kW)
Apparent Power	Kilo Watt (kW)

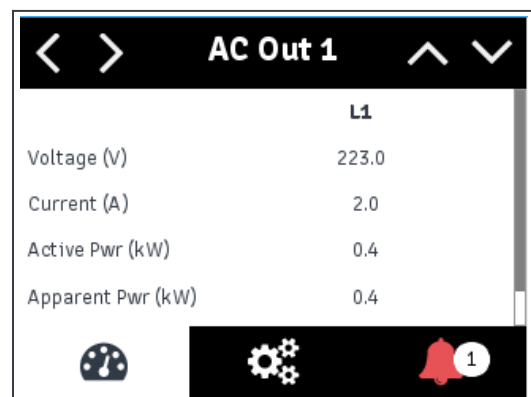

8.3.3.3 DC Page

This page displays the measurement made by the modules on the DC.

Measure	Unit
Voltage (V)	Volts (V)
Battery Current (I)	Ampere (A)
Battery Power	Kilo Watt (kW)
Load Current (A) (DC Converter Current)	Ampere (A)
Load Power (DC Converter Power)	Kilo Watt (kW)
Remaining time	Minutes

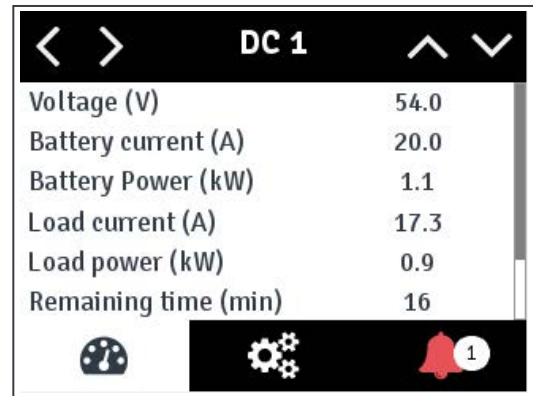

8.3.3.4 AC In Page

This page displays the measurement made by the modules on the AC output.

Measure	Unit
Voltage (V)	Volts (V)
Current (I)	Ampere (A)
Frequency (f)	Hertz (Hz)
Power	Kilo Watt (kW)

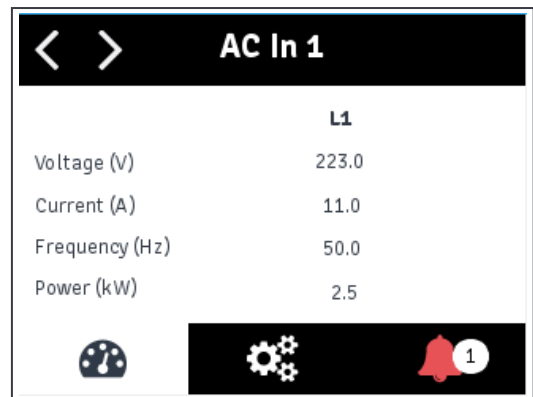

8.3.3.5 System Page

This page displays the following information in the system.

- Number of Redundancy modules
- Installed power
- Available power
- Number of configured modules and its status

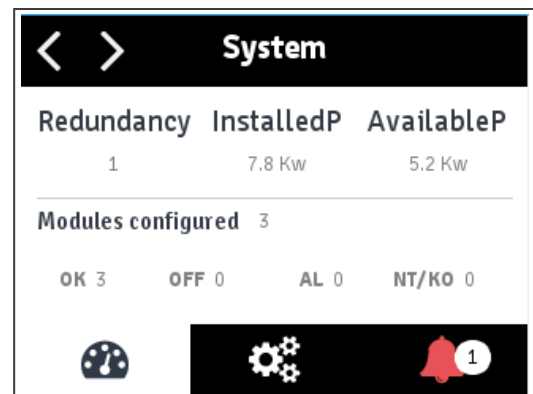

8.3.3.6 Settings Page

Clicking the *Settings* icon  on the tool bar brings the system page. In this page, quick actions are available which is often needed for on-site maintenance.

Refresh module list

As the system is modular, it's mandatory to tell it that something has changed at module level. By clicking the *Refresh module list* icon  on the toolbar, the system will scan modules, remove modules which are no more present and monitor newly populated modules.

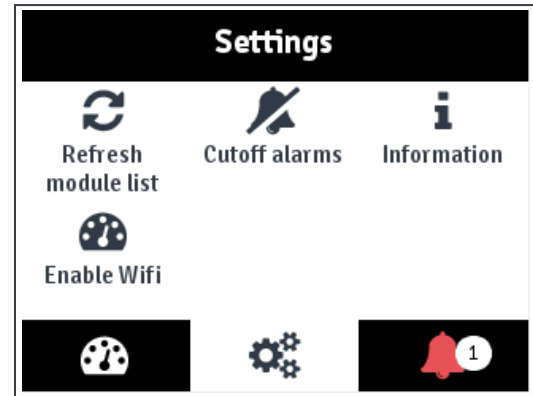

Cutoff alarms

Clicking the *Cutoff alarms* icon  on the toolbar, the following occur:

- Relays get back to their “not in alarm” state
- Buzzer sound is turned off

This behaviour is valid for all types of alarm. At the time being, SNMP, led, display ... are not impacted by the cutoff.

It's a one-time action and cannot be undo. Pressing many times the cutoff button does not change anything to behaviour (sound is **not** turned for example).

Informations

Clicking the *Informations icon*  on the toolbar, it launches a pop up listing information about the system such as MAC Address, software version and so on.

8.4 User WEB Interface

The user interface is accessible on the laptop by typing the IP address of the system in a web browser.

The default IP address is **10.250.250.1** and the password is **1234**.

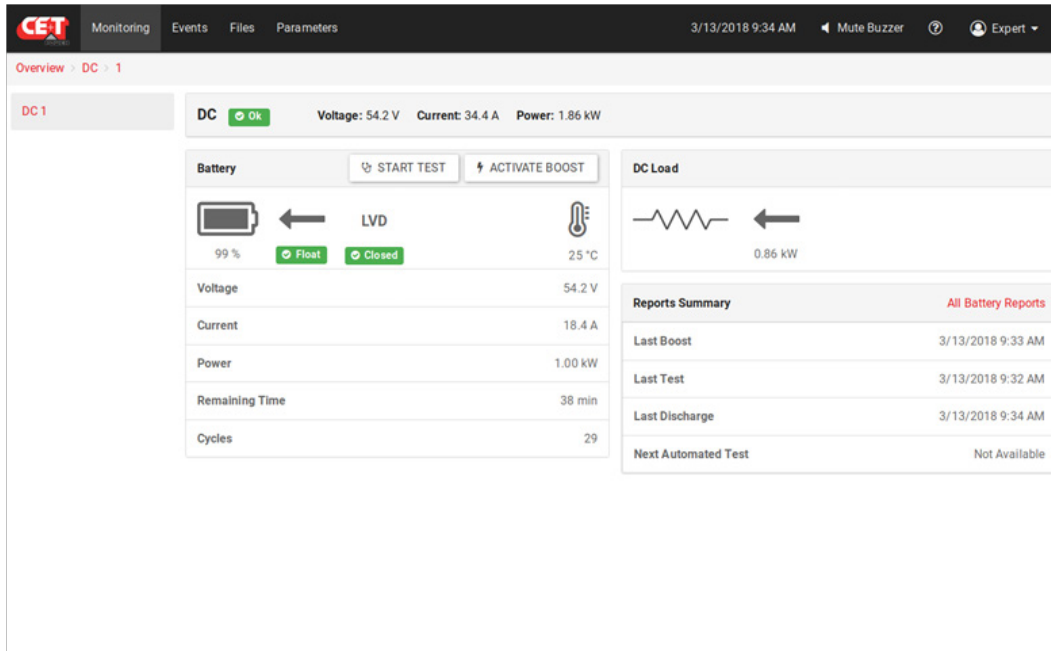

Monitoring Screen - DC Details

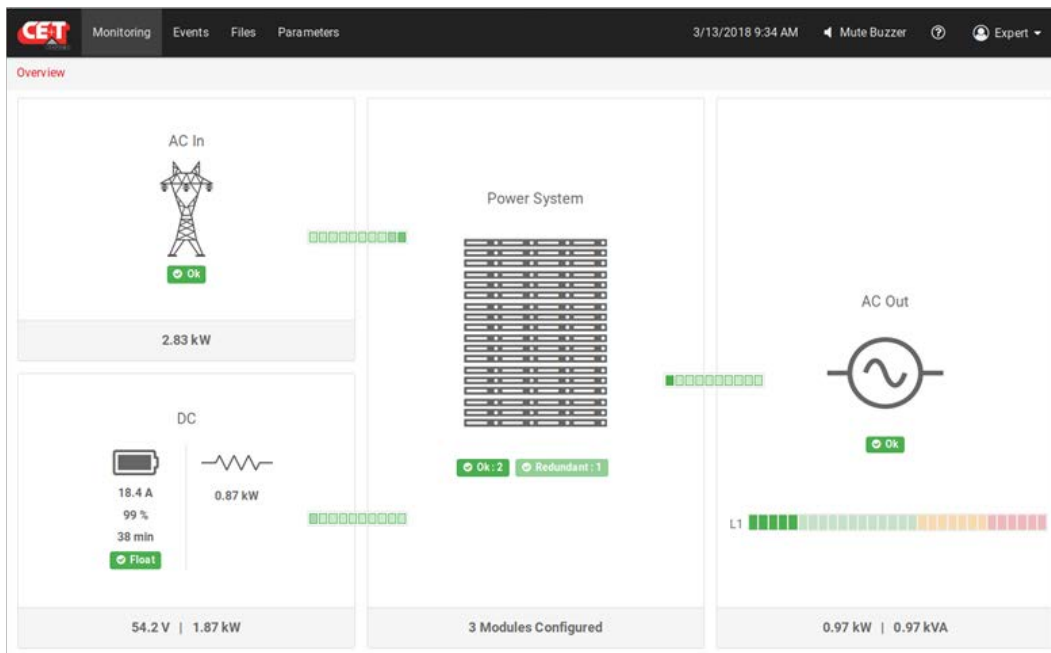

Monitoring Screen - Power Details

Operation

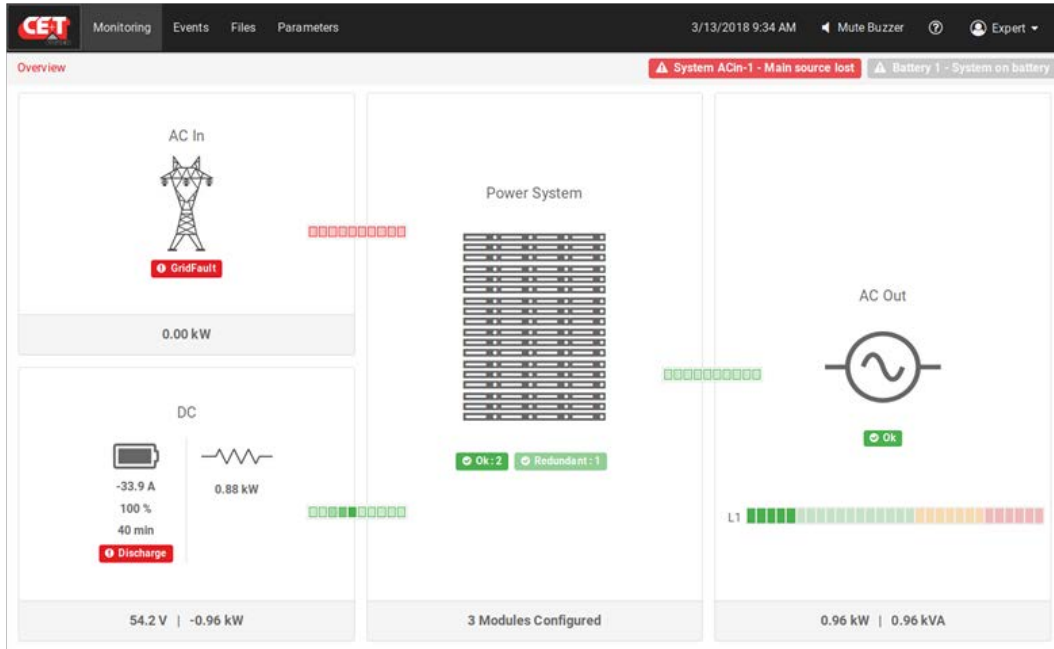

Monitoring Screen - Battery mode

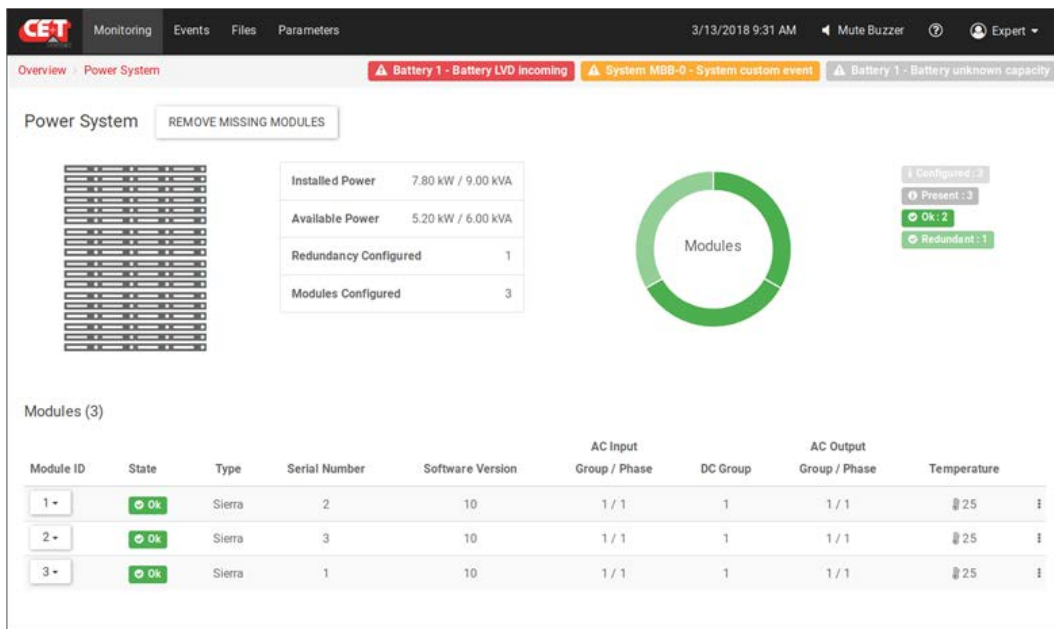

Monitoring Screen - Module details

9. System Start-up

9.1 Initial state

- System is properly installed in cabinet in accordance to section 7.2, page 18 and connected in accordance to section 7.3, page 19. Check battery polarity.
- All breakers available on drawer front face are on OPEN position.
- AC power sources is OFF.
- DC Battery breakers Q1 and Q2 are OPEN.
- Only one module is plugged in the system.

9.2 Installation Check

Warning: Before sliding the module into the system, make sure nothing is blocking the module such as objects and wires.

- Make sure that the system is properly mounted in the cabinet/floor.
- Make sure that the system is connected to Ground.
- Make sure that all DC and AC input breakers are switched OFF.
- Make sure that all cables comply with recommendations and local regulations.
- Make sure that all cables are strain relieved.
- Make sure that all breakers comply with recommendations and local regulations.
- Make sure that DC polarity complies with marking.
- Re-tighten all electrical terminations.
- Make sure that converter/controller positions are left open.
- Cover empty converter positions with blanks.
- Make sure that the Remote ON/OFF is wired appropriately for local regulations.
- Make sure that the point of AC supply meets local regulations.

9.3 Start-up

1. AC Input
 - a) Switch ON the AC power supply (protection placed outside of the system).
 - b) Inview S monitor start (~30s).
 - c) Module LEDs start fixed orange and then AC OUT stage switch ON 60s after end of Inview S startup process.



System Start-up

2. Configure the system
 - a) Send your configuration file to Inview S.
 - b) Set Inview S clock.
 - c) Clear Inview S logfile.

3. DC Start up

Warning: Make sure that string 1 and string 2 in the battery has same level of charge (see voltage) before closing Q1 and Q2.

- a) Switch ON the DC power supply Q1, Q2.
 - b) Inview S read battery voltage from Measure Box Battery board.
 - c) If battery voltage is within specified limit, LVD is switched in CLOSE state.
 - d) Module DC stage switch ON (corresponding LED green).
 - e) Battery is charged by the system (if configuration allows it and if battery is not fully charged).
4. Insert remaining modules, one by one, in the system.
 - a) All modules have the 3 left LEDs in GREEN state.
 - b) Switch ON AC output breakers Q5, Q6.
 - c) AC load is supplied by the system.
6. Switch ON DC output breakers Q3, Q4.
 - a) AC load is supplied by the system.
 - b) Battery is charged or maintained charged by the system.
7. Clear logfile.

10. Inserting/removing/replacing modules

10.1 ECI Converter

- The ECI converter module is hot swappable.
- When a new module is inserted in a live system it automatically takes the working set of parameters.
- When a new module is inserted in a live system it is automatically assigned to the next available address.

10.1.1 Removal

Notice: When one or several converter modules is/are removed access to live parts becomes possible. Replace module(s) with blanks without delay.

1. Rotate the screw in anti clockwise by using cross head screw driver to unlock the latch.
2. Hold the front handle and pull the module out.
3. Replace with a new module or a blind unit

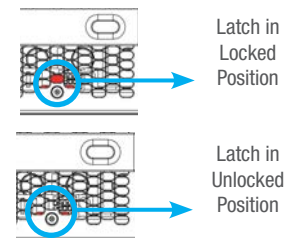
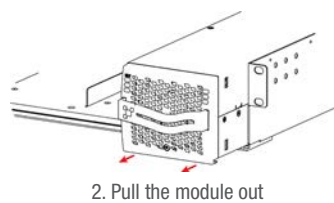
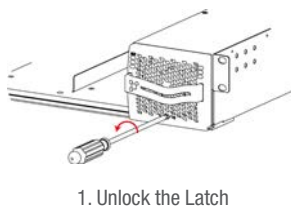

10.1.2 Inserting

1. Check module compatibility (DC Voltage!).
2. Place the module in the shelf and slide in.
3. Using the module handle, push firmly until the unit is properly connected.
4. Rotate the screw in clockwise by using cross head screw driver to lock the latch.
5. The module will start up and take the first address available on the bus.

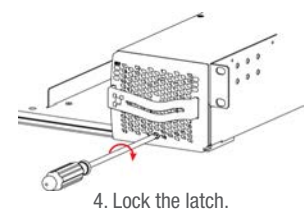
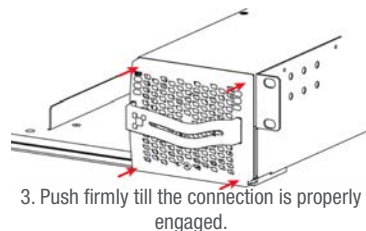
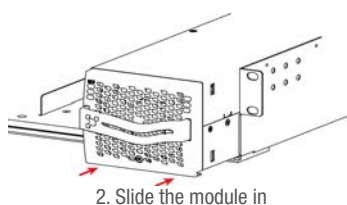

Inserting/removing/replacing modules

10.2 Fan replacement

The FAN life is approximately 60,000 (Sixty Thousand) hours. The converter modules have fan runtime meters and fan failure alarms. Fan failure can result from a failing fan or driver circuit.



1. Let the module rest at least 5 minutes before initiating work.
2. The converter front cover must be removed. Use a screw driver and remove the screws on both side of the module.
3. Free up the fan. (Note the fan connector and wires position).
4. Disconnect the supply cord, and remove the fan..
5. Replace with new fan and connect supply cord.
6. Place the front cover and tighten the screws on both sides of the module.
7. Check fan for operation.
8. Access Inview and reset the fan run time alarm from within the action menu.



11. Commissioning

DATA	
Date	
Performed by	
Site	
System serial number	
Module serial numbers	

Actions	OK / Not OK
System is running	
All module inserted inside the system.	
AC load is supplied.	
DC load is supplied.	
Battery is charged.	
Switch OFF AC IN and check that the AC and DC load continue to be supplied by Battery source.	
Switch ON AC IN and check that battery is recharged by the system.	
System recover "No alarm" state.	
Check that Battery temperature is correctly displayed	

Record the following values

Parameters	Description
Number of module seen by Inview S	
Redundancy	
AC IN	
Voltage	
Current	
Power	
AC OUT	
Voltage	
Current	
Power	



Commissioning

Parameters	Description
DC Load	
Voltage	
Current	
Power	
Battery	
Voltage	
Current	
Power	
Temperature	
Breaker status	
Q1 – BATTERY 1	
Q2 – BATTERY 2	
Q3 – DC LOAD 1	
Q4 – DC LOAD 2	
Q5 – AC LOAD 1	
Q6 – AC LOAD 2	
Download configuration file and clear logfile.	



12. Service

For Service

- Check Service Level Agreement (SLA) of your vendor. Most of the time they provide assistance on call with integrated service. If such SLA is in place, you must call their assistance first.
- If your vendor doesn't provide such assistance (*) you may call CE+T directly. Toll free Number **1(855) 669 - 4627(**)**

Service is available from 8:00 A.M. to 10:00 P.M. EST, Monday through Friday, except closing periods for holidays or inclement weather.

Major Incidents and Emergency conditions can be invoked for immediate handling of same number or by dropping a mail on customer.support@cetamerica.com (***)

(*) CE+T will redirect your call to your vendor if he has such SLA in place.

(**) Valid in USA and Canada only.

(***) Messages that are not Major Incident or Emergency will be served at the next scheduled working day.

13. Maintenance Task

As maintenance will be performed on live system, all task should be performed only by trained personnel with sufficient acknowledge on ECI product.

Tasks:

- Identify the site, customer, rack number, product type.
- Download and save configuration file for back up.
- Check configuration file to be in accordance with operational site conditions.
- Read and save log file for back up.
- Check and analyze log file, and if alarm are present.
- Replace dust filter if present. Filter is mandatory in dusty environment.
- Check module temperature and log value. If internal temperature is higher then previous year, it should be interesting analyze if it is due an increasing load or dust effect. It is common to have a delta of 15°C by 30% of load between the ambient and the internal temperature. If temperature increase due internal dust built up clean the ECI with vacuum cleaner and/or soft compressed air.
- Clean cabinet (vacuum cleaner or dry cloth).
- Control the converter mapping (AC Group, DC Group, Address).
- Check load level and record the rate value (print in word document the 4 screen modules information for the 32 modules, the 3 screen for the phases value and the 2 screens for the group AC and DC value).
- Change the configuration file for AC and DC mix mode to check that all ECI work on both power supply.
- Check alarm operation (e.g., redundancy lost, mains failure, DC failure) on dry contact and through SNMP system or web interface.
- Switch OFF AC IN and check alarms.
- Check temperature terminal and temperature wiring. If possible use an infrared camera.
- Read and record value as wave form, power factor, Crest factor, THD I from power analyzer.
- Take cabinet picture.
- Keep track of report and provide end user with a copy.

13.1 Spare Parts

Parts	Sierra 2.4 KW Single Phase	Sierra 4.8 KW Single Phase	Sierra 7.2 KW Three Phase
Sierra Rack	-	T724730010	-
Sierra Module	T721730001		
Sierra Module Blank	T721030010		
Inview S	T302004100		
Measure Box	T302006000		

